

Internal comparison measuring instrument ON / ONM for grooves and recesses

It is especially difficult to measure the diameter of a groove, because the bore gauge needs a large measuring retraction or travel. This measuring travel can generally not be offered by using bore gauges, that base on the principle of the comparison measuring.

With the Series ON / ONM, a bore gauge is available, which was especially designed for this application.

The ON basic unit with „pistol-like“ holder and pull-back lever can be used universally and can be completed with expanding probes, that are adjusted to the \varnothing to be measured, in order to cover a large application range from 6 to 200 mm.

The measuring instrument must be provided with a 1/100 dial gauge with measuring travel 10 mm.

The setting of the comparison measuring instrument is done with appropriate setting rings.

The Series ON for grand \varnothing 6 - 22 mm consists of the ON basic instrument and ON probes of your choice, each with a fixed application range.

The Series ONM consists of the ON basic unit, together with an ONM expanding probe for the application range 20 - 55 mm or 45 - 200 mm and ONM measuring slides, that are adjusted individually to the measuring task. The measuring slides are easily and quickly exchangeable.

Technical data:

Application range:	6 – 200 mm
repeatability:	0,01 mm
Deviation:	1 % of the measuring travel

Accessories and special Designs:

- Measuring depth extension
- Depth stop
- ONM measuring slides with special measuring range

For ONM (from \varnothing 20 mm):

Basic unit and ONM expanding probe with 20 mm retraction travel s (standard = 10 mm)



Basic unit ON, Measuring slide, Expanding probe ONM

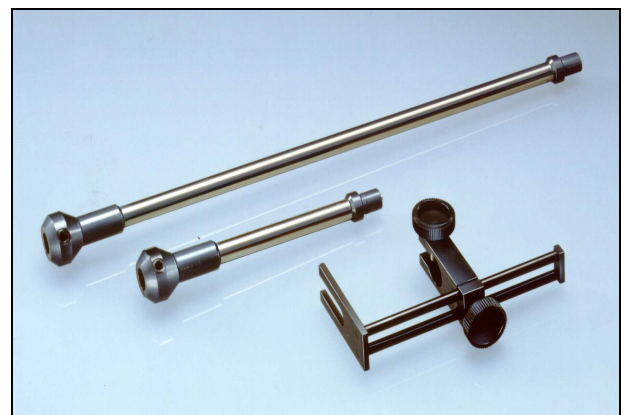

Accessory Depth Extension and Depth Stop

Probe	d ₁	d ₂	b	MT	s
ON 8	6	6 - 8	0,8	60	2
ON 12	8	8-12	1,2	60	4
ON 14	10	10-14	1,2	60	4
ON 18	12	12-18	1,2	60	6
ON 22	16	16-22	1,2	60	6
ONM 20 – 55	20 – 55	2,2	140	10	
ONM 40 - 200	40 – 200	2,5	140	10	

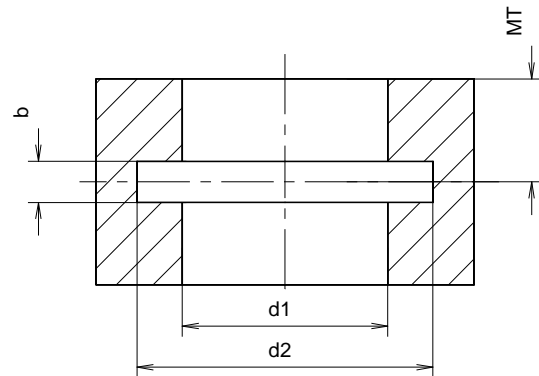

Special Designs

For applications, by which the measuring instrument capability of the expanding probe is not sufficient, the expanding probe can be integrated into a measuring sleeve.

The automatic centring and alignment of the plug gauge is done in the grand bore d_1 , the integrated probe measures the diameter d_2 of the groove.

By doing so, the same characteristics can be obtained, as in the case of a measurement with the plug gauge of the Series OD:

- self centring
- automatic alignment in the bore
- easy and quick measurement
- high measuring instrument capability
- possibility to measure automatically, using a handling device
- no search for reversal point
- possibility of SPC recording
- floating contacting

The plug gauge OD-ON is available for \varnothing from 6 to 100 mm. The maximal possible groove depth is up to 10 mm



Messdorn ON-OD

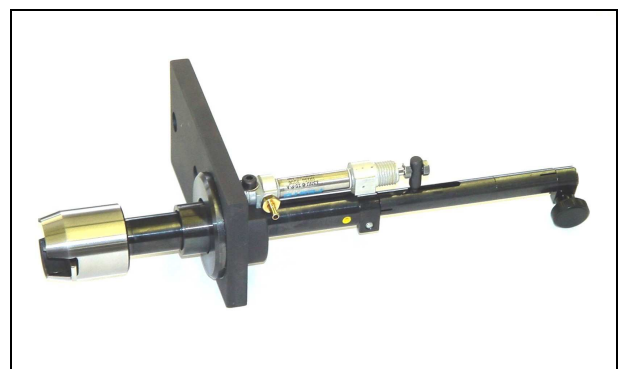

Design with floating holder and pneumatic retraction for automatic measuring device