

SUBITO® Precision Bore Gauge

SL

for measuring bores w. boring bar left in the workpiece

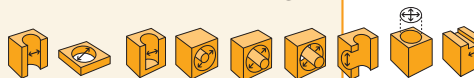

SERIES 150-154

Self-centring bore gauge for determining bore diameters, for instance with boring bar left in the workpiece.

Design: meas. instrument w. column (mm- or inch-graduation) for pre-setting of the diameter, in wooden box, w/o dial gauge.

SUBITO® SL

Application range [mm]	max. Ø of boring bar [mm]	Meas. depth [mm]	Art.-No.
25 - 70	45	12	150 0000
35 - 105	70	17,5	151 0000
100 - 210	130	30	152 0000
100 - 280	130	30	153 0000
200 - 500	220	30	154 0000
[inch]	[inch]	[inch]	
1.00 - 2.75	1.77	0.47	150 0000 I
1.38 - 4.33	2.76	0.69	151 0000 I
3.94 - 8.27	5.12	1.18	152 0000 I
3.94 - 11.02	5.12	1.18	153 0000 I
7.87 - 19.68	8.66	1.18	154 0000 I



SUBITO® SL

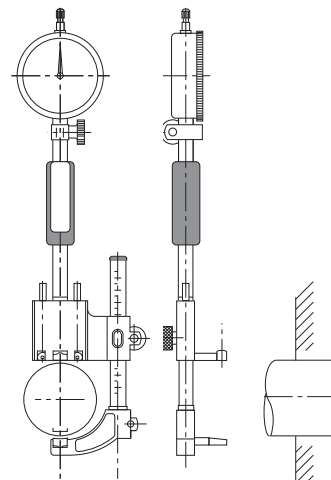

Inspection Certificates for SCHWENK measuring instruments see p.32