

# SUBITO® Setting Device ESU

SERIES 125

FOR SETTING TWO-POINT COMPARATOR PRECISION BORE GAUGES WITH THE HELP OF GAUGE BLOCKS

## Delivery ESU:

frame with setting jaws holder, pair of setting jaws, tungsten carbide measuring anvils in gauge block quality, clamping unit, stand, in wooden box; without gauge blocks

## FOR SUBITO® SU/SK/SW/SMT/SP/SV

setting range [mm]	Code
4,5 - 35	125 0000
4,5 - 160	125 0001
4,5 - 290	125 00029
18 - 160	125 00028
18 - 290	125 00002
160 - 510	125 00003
160 - 800	125 00030
160 - 1.200	125 00043
160 - 1.500	125 00045
160 - 2.000	125 00046

models for bore gauges of other brands on inquiry

for series	setting range [mm]	Code
SS	20 - 300	125 00005
SS	20 - 600	125 00038
ST	30 - 220	125 00006
ST	180 - 530	125 00007
OD-K/OD-KK	130 - 300	125 00034
OD-K/OD-KK	130 - 500	125 00035

## SPARE PARTS

setting range [mm]	Code
setting jaws holder with straddling lever (suitable for all setting jaws pairs, except SP)	125 00008
Pair of setting jaws with stay bolt and nut	
4,5 - 35	125 00009
18 - 290	125 00011
20 - 300	for SS 125 00012
30 - 220	for ST 125 00013
6 - 160	with setting jaws holder for SP 125 00014
prism pair for OD cross sleeves / cross sleeves with runners	125 00033
pair of tungsten carbide measuring anvils for ESU 4,5 - 300	125 00015
pair of tungsten carbide measuring anvils for ESU 160 - 800	125 00036



ESU Setting Device with vertical measuring axis

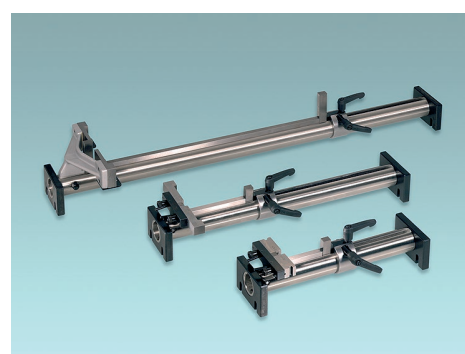

ESU Setting Device 510/290/160 with horizontal measuring axis



ESU accessories setting jaws/ measuring anvil

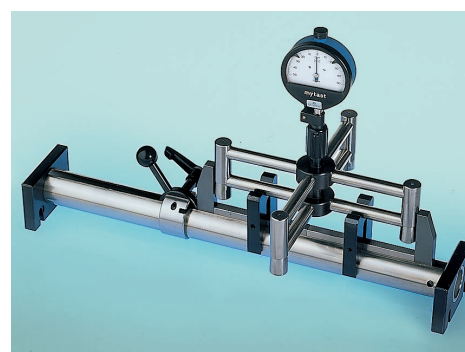

ESU Setting Device for OD cross sleeves/ cross sleeve with runners